

STT 3000 Series STT250

SMART TEMPERATURE TRANSMITTER

Models STT25H, STT25M, STT25D

EN01-6031 9/08

PRODUCT SPECIFICATION SHEET

OVERVIEW

Honeywell's STT 3000 family of microprocessor based smart temperature transmitters includes both the Series STT250 described in this specification sheet and the higher performance STT350 described in Product Specification Sheet EN01-5222. The STT350 offers high performance and advanced functionality.

The STT250 units offer competitive performance in a more compact module and with a wider range of smart communications protocols.

Choose the unit to meet your application needs :

- **STT25H** with HART™ protocol when this popular protocol is preferred. Configuration of the HART unit can be made with any of the listed HART Communication Foundation tools.
- **STT25M** for 4-20mA operation and local/ remote configuration via Honeywell's digital DE protocol from the Smart Field Communicator (SFC) or Smart Configuration Toolkit PC based software (SCT).
- **STT25D** with digital DE protocol for either 4-20mA operation or digital integration into the TDC 3000™/ TPS 3000™ control system.

Note that the latest addition to the STT250 family is the Dual Input **STT25T**. The two sensor inputs may be used for sensor cross checking or for sensor redundancy. This is described in separate Product Specification Sheet EN01-6091.

All units support the same wide range of primary sensor types, are 2 wire powered and give an output linearised to temperature over the 2 power wires. Leadwire compensation is provided for RTD (Resistance Temperature Detectors) and internal digital cold junction compensation is provided for Thermocouples. MilliVolt and Ohms sensor inputs can also be accepted.

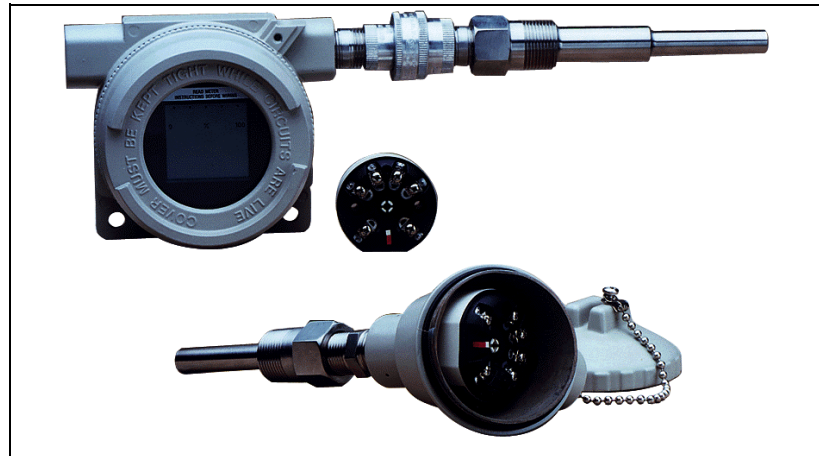

FEATURES

- Smart communication protocols available include HART or DE Honeywell.
- Direct sensor head mounting in DIN Form A housing. Housing materials available include plastic, aluminium, 316SS and cast iron.
- Mounting options include wall, pipe, DIN rail or direct sensor head mounting with or without a housing.
- Single model accepts input signal from a wide choice of primary sensors to satisfy varying application requirements with minimum transmitter inventory.
- Suitable for 4, 3 or 2 wire Pt100 and Pt200 RTD measurement.
- Hard wired upscale/ downscale failsafe link to ensure secure operation in the event of a failure.
- Open circuit sensor analysis carried out in every measurement cycle.
- Selectable latching/non-latching failsafe operation for open circuit sensor.
- Integral analogue or digital indication meter option.
- Analogue to Digital converter validated frequently.

DESCRIPTION

The STT250 transmitters are suitable as replacements for any conventional or most smart temperature transmitters in use today. The memory contains the characteristics of most commonly used temperature sensors.

You can easily use the hand held communicator or PC tool to configure the transmitter for any of these sensors and it will automatically correct for their associated non-linearity's.

Accuracies stated below are available merely by selecting the sensor type and range (i.e. without user calibration).

Calibration of the LRV/URV end points will typically give accuracy improvements of 2 times. Sensor errors can be calibrated out by calibration to the specific sensor either by having it at the LRV/URV temperatures or by simulation of the known values.

In addition, all units pass through Environmental Stress Screening by fast cycling between -40°C and +85°C to ensure maximum product reliability. During this process the ambient temperature coefficients are determined for each unit and burned into memory to ensure temperature compensation over a wide range of operating conditions.

Configuration adjustments and diagnostics checks can be made either locally or remotely over the signal wires from anywhere along their route. This enables major savings in manpower time during commissioning, start up and maintenance activities.

Performance Under Rated Conditions

Sensor	Digital Accuracy over Normal Range		D/A Accuracy % of span	Digital Accuracy over Maximum Range		Standards
	°C	(°F)		°C	(°F)	
Pt100	0.15C	for -200 to 450 (-328 to 842)	0.025%	0.25C	for -200 to 850C (-328 to 1562)	IEC751(ITS-90)($\alpha=0.00385$)
Pt200	0.30C	for -200 to 450 (-328 to 842)	0.025%	0.40C	for -200 to 850C (-328 to 1562)	IEC751(ITS-90)($\alpha=0.00385$)
Pt100J	0.15C	for -200 to 450 (-328 to 842)	0.025%	0.25C	for -200 to 640C (-328 to 1184)	JISC1604-81($\alpha=0.00392$)
Ω	0.40 Ω for 0 to 1000 Ω		0.025%	0.40 Ω for 0 to 2,000 Ω *		
mV	15 μ V for -20 to 120mV		0.025%	15 μ V for -20 to 120mV		
B	1.0C	for 550 to 1820 (1022 to 3308)	0.025%	3.0C	for 200 to 1,820C (392 to 3308)	IEC 584-1(ITS-90)
E	0.30C	for 0 to 1000 (32 to 1832)	0.025%	0.60C	for -200 to 1,000C (-328 to 1832)	IEC 584-1(ITS-90)
J	0.30C	for 0 to 800 (32 to 1472)	0.025%	0.70C	for -200 to 1,200C (-328 to 2192)	IEC 584-1(ITS-90)
K	0.60C	for -120 to 1370 (-191 to 2498)	0.025%	0.90C	for -200 to 1370C (-328 to 2498)	IEC 584-1(ITS-90)
N	0.40C	for 0 to 1300 (32 to 2372)	0.025%	1.5C	for -200 to 1300C (-328 to 2372)	IEC 584-1(ITS-90)
R	0.60C	for 500 to 1760 (932 to 3200)	0.025%	1.0C	for -50 to 1760C (-58 to 3200)	IEC 584-1(ITS-90)
S	0.60C	for 500 to 1760 (932 to 3200)	0.025%	1.0C	for -50 to 1760C (-58 to 3200)	IEC 584-1(ITS-90)
T	0.30C	for -100 to 400 (-148 to 752)	0.025%	0.5C	for -250 to 400C (-418 to 752)	IEC 584-1(ITS-90)

* 4 wire ohms input only and limited to 0 to 1,000 Ohms for model STT25D

SPECIFICATIONS

Operating Conditions

Parameter	Reference Condition	Rated Condition	Operative Limits	Transportation And Storage
Ambient temperature °C	23 °C \pm 2	-40 to +85	-40 to +85	-50 to +100
Humidity				
Rack mounted % RH	10 to 55	5 to 95	5 to 100	5 to 100
In field housing % RH	10 to 55	5 to 100	5 to 100	5 to 100
Supply voltage	Voltage range 10.8 to 35 Vdc at the transmitter terminals			
Output current	Current overrange 3.8 to 20.8 mA. Failsafe limits < 3.8 and 21.8 mA			
Load resistance	0 to 1110 Ω			
Vibration	Maximum of 4g over 15 to 200Hz (restricted to 3g with indication meter).			
Shock	Maximum of 40g.			

Performance Specifications

Output D/A accuracy: $\pm 0.025\%$ of span

Cold Junction accuracy: $\pm 0.5^\circ\text{C}$

Total reference accuracy: Analogue 4-20mA mode = Digital accuracy + Output D/A accuracy + CJ accuracy (T/Cs only)

Total reference accuracy: Digital DE mode = Digital accuracy + CJ accuracy (T/Cs only).

(example: transmitter operating in analogue mode with Pt100 sensor and 0 to 200°C range.

Total reference accuracy =

$0.15 + (200/100) \times 0.025 = 0.2^\circ\text{C}$.

Digital ambient temperature effect (per 10°C change from 23°C ref.): RTDs or Ohms : 0.050% of reading in Ohms.
: T/Cs or mV : 0.080% of reading in mV.

Output D/A ambient temp. effect (per 10°C change from 23°C ref.): $\pm 0.045\%$ of span.

Cold Junction ambient temperature effect: 40: 1 rejection for ambient temperature changes from 23°C reference.

Total output ambient temperature effect : Analogue 4-20mA mode = Digital effect + Output D/A effect + CJ effect (T/Cs only).

Total output ambient temperature effect: Digital DE mA mode = Digital effect + CJ effect (T/Cs only).

Power supply voltage effect: 0.005% of Max span per Volt.

Stability/time drift: 0.05% of max span per year.

Additional Parameters

Output: 4-20mA or Honeywell digital DE protocol. HART and DE available with 4-20mA output.

Adjustment range: No limits to adjustments within the Maximum Range except minimum span limit of 1 engineering unit e.g. 1°C

Damping time constant: Adjustable from 0 to 102 seconds digital damping.

Output response time: 1 second to reach 63% of final value with 0 secs damping.

Output update time

0.5 secs approximately.

Input/ output galvanic isolation Withstands 500Vac dielectric strength test for 1 minute.

Sensor open circuit

Open circuit/ burnout detection is user selectable. Upscale or downscale with critical status message. Latching or non-latching sensor burnout action.

Common mode rejection

120dB (1 million to 1) from 50Hz to 50 kHz.

Series mode rejection

40dB (100 to 1) for 50 or 60Hz $\pm 0.5\text{Hz}$. (with internal software filter set to local power line frequency).

EMC compliance

In compliance with 89/336/EEC, ElectroMagnetic Compatibility (EMC) Directive.

RFI rejection: $\pm 0.1\%$ of span at 30V/m over 20 to 1,000MHz in metallic housing and with shielded cables.

Physical Mounting, Construction and Integral Meters

The STT250 Temperature Transmitter is designed to be mounted in a DIN Form A housing for direct installation with the temperature sensor or can be provided in a remote pipe or wall mount housing. Details on the various housings and integral meters available are given in specification sheet EN01-6032. The STT250 Temperature Transmitter module can also be DIN rail mounted to a top hat or "G" rail via a clip.

STT250 Module Dimensions (in mm)

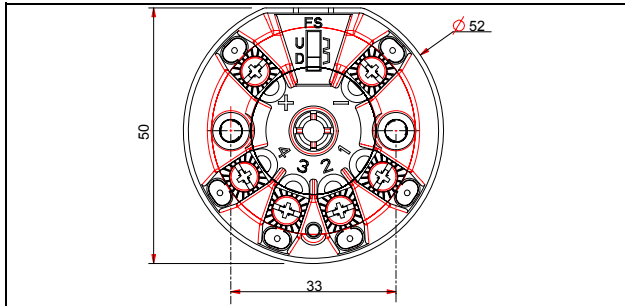
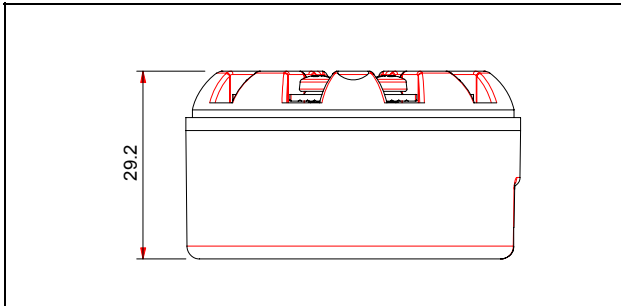

STT250 Connections

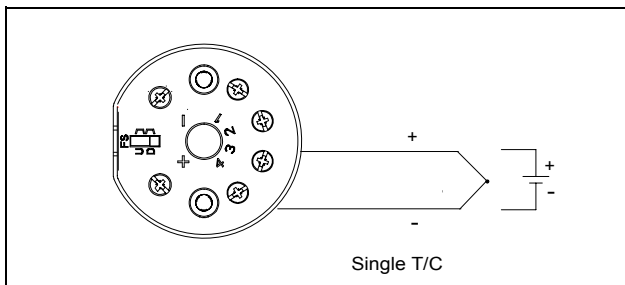
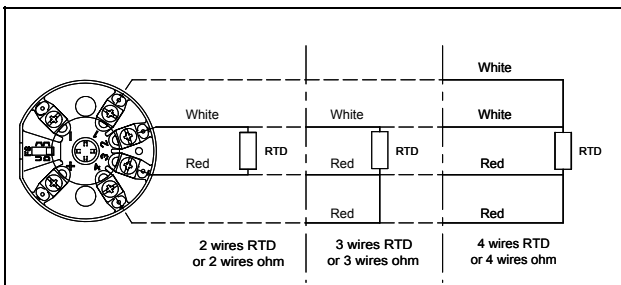

Materials of Construction

Terminal Block	Noryl
Connection Screws	M3 Nickel plated brass
Module Housing	Cycloy (PC/ABS) with metallised interior surface
Weight	0.075 kg (0.2 lbs)

Approvals

The STT250 Temperature Transmitter module is Intrinsically Safe to ATEX, IECEx, FM and CSA standards when used with a suitable safety barrier. It is zone 2 and explosion-proof to ATEX, IECEx, FM and CSA standards when installed in a suitable housing. See the Model Selection Guide Table VII in this Specification Sheet for detailed safety approvals covering both the STT250 module only or for the STT250 module supplied in a housing.

Probe and Thermowell Availability

STT250 can be supplied complete with any of the previously listed thermocouple or RTD sensors and with any of a wide range of thermowells. The sensors are of Mineral Insulated (MI) construction with lengths of up to 2 meters available. For the direct head mount installation the sensor is supplied with a mounting plate for STT250 module attachment and fixing screws to provide the spring loaded attachment to the housing. For EEx d IIC T6 applications a flame trap is included between the sensor and sensor entry of the housing. See details on the standard sensors available in EN01-6033 for Europe, or 34-44-29-01 for North America.

The range of thermowells available as a total thermal solution cover almost every possible requirement :

Materials:	Carbon Steel, 304SS, 316SS, 316L SS, Hastelloy C-276, Monel 400, Inconel, and many others
Thermowell Types:	Threaded or flanged, with or without lagging and solid drilled, forged or fabricated construction
Flange Types:	Raised Face, Flat Face and Ring Type joint flanges available in 1 to 3 inch sizes or 15 to 200mm
Flange Ratings:	ANSI 150 to 2500, BS 4504 NP6 to NP100, BS 10 Tables D to K and API 6A 5000 to 15000lb

Other materials, types and accessories are available on request.

Model Selection Guide
34-44-16-03 Issue 29

Instructions

- Choose availability column based on mounting configuration.
- A dot (•) denotes unrestricted availability. A letter denotes restricted availability.
- Blank denotes unavailable - choose alternate mounting. Restrictions follow Table VII.
- Select the desired Key Number based on the desired communications protocol.
- Select options and approvals from Tables.



HOW WILL THE UNIT BE MOUNTED?

- Module only (no housing), to be DIN rail or wall mounted
- Module to be "head mounted" directly to the sensor in smaller housing
- Module to be "field mounted" in Explosion-Proof housing remotely from or directly to the sensor

Key Number

Description	Selection	Availability		
Smart Temperature Transmitter Module				
4-20mA Output, SFC/SCT Configurable	STT25M	•	•	•
HART 5, Protocol, 4-20mA Output	STT25H	•	•	•
HART 6, Protocol, 4-20mA Output	STT25S	•	•	•
Digital DE/ 4-20mA Output, for Digital Integration	STT25D	•	•	•
Dual input, HART Protocol, 4-20mA output	STT25T	•	•	•
All modules carry the following approvals: CE Mark for compliance to EN 50081-2 and 50082-2 Russian Certificate of Pattern Approval No. 2064 of Jan. 1998 Choose additional safety approvals required in Table VII				

TABLE I - Sensor, Probe and Thermowell Accessories

No Integral Sensor Probe or Thermowell Supplied	0	•	•	•
---	---	---	---	---

TABLE II - Transmitter Housing and Integral Meters (Reference EN01-6032 for details)

Housing	No Housing Supplied	0 _ _			•
	Field Explosion-Proof Aluminum with Beige Epoxy Coating	E _ _	•		
	Mount (2) Explosion-Proof 316 Stainless Steel	T _ _	•		
	Head Mt Type 4X housing - Beige	C _ _		•	
Cable/ Conduit Entry	Not Applicable - No Housing Supplied	_ 0 _			•
	1/2" NPT Cable/ Conduit Entry	_ N _	•	•	
	M20 x 1.5 Cable/ Conduit Entry	_ M _		•	
Integral Meter	No Integral Meter Supplied	_ _ 0	•	•	•
	Analog Meter for Field Mount Housing	_ _ M	•		
	E.U. Meter for Field Mount Housing	_ _ E	h		
	Smart Meter for Field Mount Housing (3)	_ _ S	i		

(2) With a Field Mount Housing, 20 characters max. of customer information is available on the nameplate at no charge. (See 13:STT-OE pages for ordering instructions.)

(3) For the STT25D and STT25M transmitters

HOW WILL THE UNIT BE MOUNTED?

Module only (no housing), to be DIN rail or wall mounted

Module to be "head mounted" directly to the sensor in smaller housing

Module to be "field mounted" in Explosion-Proof housing remotely from or directly to the sensor

Availability

TABLE III - Configuration, Tagging and Manual

		Selection	Availability		
Configuration	None - Factory Default Configuration Supplied	0 __	•	•	•
	Transmitter Configuration (See 13:STT-OE pages for choices)	T __	•	•	•
Customer Tagging (4)	No Tagging Required	_ 0 _	•	•	•
	316 SS Wired-on Customer I.D. Tag (4 lines, 28 chars. per line, customer specified information)	_ T _	•	•	
	316 SS Wired-on Customer I.D. Tag (blank)	_ B _	•	•	
Operator's Manual (5)	None	__ 0	•	•	•
	English Language Version	__ E	•	•	•
	French Language Version	__ F	•	•	•
	Spanish Language Version	__ S	b	b	b
	Chinese Language Version	__ C	b	b	b

TABLE IV - Optional Equipment

Mounting Arrangement	No Mounting Arrangement Supplied	0 __	•	•	•
	Carbon Steel Mounting Bracket for 2" Pipe	M __	•		
	Stainless Steel Mounting Bracket for 2" Pipe	S __	•		
	Spring Loading Mounting set	L __		•	•
	DIN Rail Mounting via Clip (to Top Hat or "G" Rail)	D __			•
316 SS Conduit Adaptor for Wiring Entry	No Adaptor(s) Supplied	_ 0 _	•	•	•
	1/2" NPT to M20 x 1.5 (EEx d IIC approved)	_ 1 _	•	•	
	1/2" NPT to 3/4" NPT	_ 2 _	•	•	
	1/2" NPT to 3/4" NPT	_ 3 _	•		
Lightning Protection	No Lightning Protection Supplied	__ 0	•	•	•
	Externally Mountable to Field Mount Housing	__ L	e		
	Internal Surge/ Lightning Protection	__ S	•		

TABLE V - Optional Extended Warranty Coverage & Certificates

Optional Extended Warranty	Standard Warranty	0 __	•	•	•
	Additional Warranty - 1 year	1 __	•	•	•
	Additional Warranty - 2 years	2 __	•	•	•
	Additional Warranty - 3 years	3 __	•	•	•
Optional Certificate (5)	No Transmitter Configuration/ Calibration Certificate	_ 0 _	•	•	•
	Transmitter Configuration/ Calibration Certificate	_ D _	•	•	•
	FMEDA (SIL) + Config./ Calibration Certificate	_ S _	g	g	g
	No Certificate of Conformance/ Origin	__ 0	•	•	•
Certificate of Conformance/ Origin	Certificate of Conformance/ Origin	__ C	•	•	•
	FMEDA (SIL) + Conformance/ Origin Certificate	__ S	g	g	g

TABLE VI - Additional Features

SIL2	No SIL2 - TUV Certified Transmitter	00	•	•	•
	SIL2 - TUV Certified Transmitter (requires HART 6)	S2	d	d	d

(4) Full model number does not appear on module or head mount housing. If model number is to appear on unit, order wired on tag.

(5) Chosen Operator's Manuals and chosen Certificates are automatically shipped with unit. See 13:STT-OE pages for additional manuals and alternate shipping.

HOW WILL THE UNIT BE MOUNTED?

Module only (no housing), to be DIN rail or wall mounted

Module to be "head mounted" directly to the sensor in smaller housing

Module to be "field mounted" in Explosion-Proof housing remotely from or directly to the sensor

Availability

TABLE VII - Safety Approvals (6)

Approval Body	Approval Type	Location or Classification	Selection			
None	No approval body certifications included		00	•	•	•
Factory Mutual	Explosion-Proof	Class I, Div. 1, Groups A,B,C,D	1C	f		
	Dust Ignition-Proof	Class II, III Div. 1, Groups E,F,G				
	Intrinsically Safe	Class I, II, III, Div. 1, Groups A,B,C,D,E,F,G				
	Non-Incendive	Class I, Div. 2, Groups A,B,C,D Suitable for Class II, III, Div. 2, Groups F, G				
	Outdoor Location	Enclosure Rated NEMA 4X	1J		•	
	Explosion-Proof	Class I, Div. 1, Groups B,C,D				
	Dust Ignition-Proof	Class II, III, Div. 1 Groups E,F,G				
	Intrinsically Safe	Class I, II, III, Div. 1, Groups A,B,C,D,E,F,G				
	Non-Incendive	Class I, Div. 2, Groups A,B,C,D Suitable for Class II, III, Div. 2, Groups F, G	1G		•	
	Outdoor Location	Enclosure Rated NEMA 4X				
	Intrinsically Safe	Class I, II, III, Div. 1, Groups A,B,C,D,E,F,G				
	Non-Incendive	Class I, Div. 2, Groups A,B,C,D Suitable for Class II, III, Div. 2, Groups F, G				
Outdoor Location	Enclosure Rated NEMA 4X	1G		•	•	
Intrinsically Safe	Class I, Div. 1, Groups A,B,C,D					
Non-Incendive	Class I, Div. 2, Groups A,B,C,D	2J	q			
Explosion-Proof	Class I, Div. 1, Groups B,C,D					
Dust Ignition-Proof	Class II, III, Div. 1, Groups E,F,G					
Intrinsically Safe	Class I, II, III, Div. 1, Groups A,B,C,D,E,F,G					
Non-Incendive	Class I, Div. 2, Groups A,B,C,D Suitable for Class II, III, Div. 2, Groups F, G					
Outdoor Location	Enclosure Rated Type 4X					
CSA	Intrinsically Safe	Class I, II, III, Div. 1, Groups A,B,C,D,E,F,G	2G	q		
	Non-Incendive	Class I, Div. 2, Groups A,B,C,D Suitable for Class II, III, Div. 2, Groups F, G				
	Outdoor Location	Enclosure Rated Type 4X				
	Intrinsically Safe	Class I, Div. 1, Groups A,B,C,D	2G		q	q
	Non-Incendive	Class I, Div. 2, Groups A,B,C,D				
	Outdoor Location	Enclosure Rated Type 4X				
ATEX*	Intrinsically Safe Zone 0/1	Ex II 1 G Ex ia IIC T6, T5, T4 (Module)	3S	•	•	•
	Flameproof, Zone 1	Ex II 2 G Ex d IIC T6, T5, T4 Enclosure rated IP 66/67	3D	p		
	Non-Sparking Zone 2	Ex II 3 G Ex nA, IIC T6*	3N	•	•	•
	Multiple Marking** Int. Safe, Zone 0/1, or Flameproof, Zone 1, or Non-Sparking, Zone 2	Ex II 1 G Ex ia IIC T6, T5, T4 Ex II 2 G Ex ia IIC T6, T5, T4 Ex II 3 G Ex nA, IIC T6 (Honeywell) Enclosure Rated IP 66/67	3H	p		

continued next page

TABLE VII - Safety Approvals (6) Continued

Approval Body	Approval Type	Location or Classification	Selection			
IECEX	Flameproof, Zone 1 (with IS transmitter)	Ex d IIC; T6 (Ta = -50 to +80°C) T5 (Ta = -50 to +85°C) Ex tD A21 IP6X T80°C (Ta = -50 to +80°C) Ex tD A21 IP6X T95°C (Ta = -50 to +85°C)	CB	•	•	•
	Intrinsically Safe Zone 0/1	Ex ia IIC; T6 (Ta = -50 to +40°C) T5 (Ta = -50 to +55°C) T4 (Ta = -50 to +85°C)	CS	•	•	•
INMETRO (Brazil)	Flameproof, Zone 1	BR Ex d IIC T6, T5, T4 Enclosure rated IP 66/67	6D	p		
	Intrinsically Safe, Zone 0/1	BR Ex ia IIC T6, T5, T4 (Module)	6S	b	b	b

(6) The module itself is rated intrinsically safe, IP20. An appropriately rated enclosure is required for Outdoor and Dust locations.

* Module must be installed in IP54 or better housing for Zone 2 approval validity.

** The user must determine the type of protection required for installation of the equipment. The user shall then check the box () adjacent to the type of protection used on the equipment certification label. Once a type of protection has been checked on the label, the equipment shall not be reinstalled using any of the other certification type.

RESTRICTIONS

Restriction Letter	Available Only With		Not Available With	
	Table	Selection	Table	Selection
b			Key No.	STT25T
d	Key No.	STT25S		
e			VII	3D
f	II	EN0, TN0,	I	1
g	Key No.	STT25H, STT25M		See Note 6
h	II	STT25H, STT25T, STT25M	Key No.	STT25D
i	II	STT25M, STT25D	Key No.	STT25H, STT25T
p	II	E __, T __	I	1
q			VII	STT25S

Notes: (6) The module itself is rated intrinsically safe, IP20. An appropriately rated enclosure is required for Outdoor and Dust locations.

See 13:STT-9 or Operator's Manual EN11-6190 for part numbers.

See 13:STT-OE pages for Order Entry Information including tagging, transmitter configuration, manuals, certificates, drawings and SPINS.

To request a quotation for a non-published "special", fax RFQ to Marketing Applications at (1) 602 313-6155.

Distributor :



Honeywell Process Solutions

Honeywell Inc.

In the U.S.A.: Honeywell 2500 W. Union Hills Dr., Phoenix, AZ 85027, (602) 313-5000

In Europe: Honeywell PACE, 3 Avenue de Schipol, B-1140 Brussels, Belgium, (32) 2-728-2111

In Asia: Honeywell Asia Pacific Inc., Honeywell Building, 17 Changi Business Park, Central 1, Singapore 486073. (65) 355 2828

In the Africa & Middle East Region, Honeywell SpA, Via Vittor Pisani 13, 20124 Milano, Italy, (39-2) 67731

Mediterranean:

In Canada: The Honeywell Centre, 155 Gordon Baker Rd., North York, Ontario M2H 3N7, 1-800-461-0013

In Latin America: Honeywell Inc., 14505 Commerce Way, Suite 500, Miami Lakes, Florida 33016-1556, (305) 3642300